

## Features

- 6<sup>th</sup>-order Butterworth Low-Pass Filter
- Integrated Input Clamp And Level Shift Circuit
- SAG correction reduces AC coupling capacitor size
- High Slew Rate: 38V/ $\mu$ s
- Very Low Quiescent Current: TPF110 3.9mA (Typ.), TPF110L 1.9mA (Typ.)
- Super Low Stand-By Mode: 0.5 $\mu$ A (Typ.)
- AC- or DC-Coupled Output Driving Dual Video Loads (75 $\Omega$ )
- Excellent Video Performance: Differential Gain 0.4%, Differential Phase 0.7°
- High Input And Output Isolation(Disable):96 dB @1MHz
- 6dB Gain(2V/V), Rail To Rail Output
- Wide Power Supply: +2.85V To +5.5V, Single Supply
- Improved High Performance ESD And Surged Immunity Capability:
  - HBM 8KV, CDM 2KV
- Green Product, Small Size SC70 Package

## Applications

- Video Signal Amplification
- Set-Top Box Video Driver
- PVR、DVD Player Video Buffer
- Video Buffer for Portable or USB-Powered Video Devices
- HDTV

## Description

The TP110/TP110L is a single rail-to-rail 6<sup>th</sup>-order output reconstruction filter with a -3dB roll-off frequency of 9MHz and a slew rate of 38V/ $\mu$ s, with input signal DC restoration accomplished with an internal sync tip clamp. Operating from single supplies ranging from +2.85V to +5.5V and sinking an ultra-low 3.9mA quiescent current, the TP110/TP110L is ideally suited for low power, battery-operated applications. It also features inputs capable of reaching down to 0.3V below the negative rail. Additionally, an enable high pin shuts the part down in under 45ns.

The TP110/TP110L is designed to meet the needs for very low power and bandwidth required in battery-operated communication, instrumentation and modern industrial applications, such as video on demand, cable set-top boxes, DVD players and HDTV. The TP110/TP110L is offered in a space saving SC-70 package guaranteed to a 1mm maximum height constraint and specified for operation from -40°C to +85°C temperature range.

## Related Resources

AN-1201: Application notes of TPF1xx

## Function Block

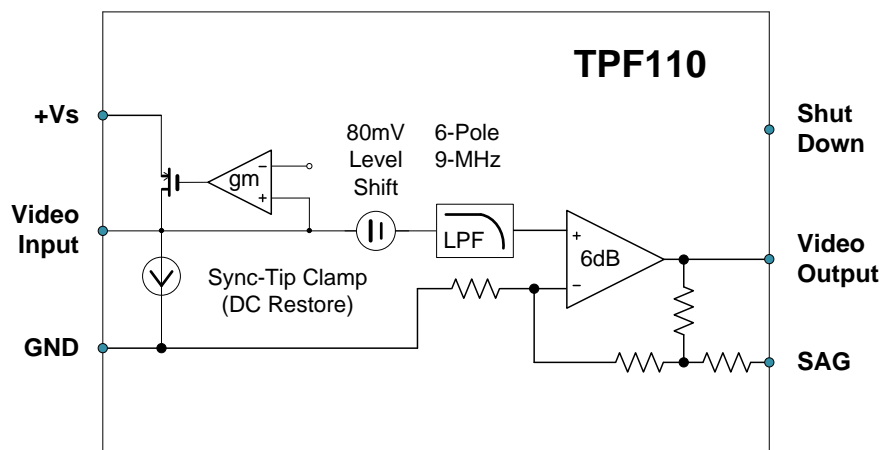

**TPF110/TPF110U/TPF110L**  
**Ultra-low Power Video Filter with Shut-down & SAG Correction**

**Order Information**

Order Number	Marking Information	Operating Temperature Range	Package	Transport Media, Quantity
TPF110-CR	F0YW <sup>(1)</sup>	-40 to 85°C	6 Lead SC70	7" Tape and Reel, 3,000pcs
TPF110U-TR	F0UYW <sup>(1)</sup>	-40 to 85°C	6 Lead SOT23	7" Tape and Reel, 3,000pcs
TPF110L-CR	F0LYW <sup>(1)</sup>	-40 to 85°C	6 Lead SC70	7" Tape and Reel, 3,000pcs

Note: (1). 'YW' is date coding scheme. 'Y' stands for calendar year, and 'W' stands for single workweek coding scheme.

**Pin configuration (Top View)**

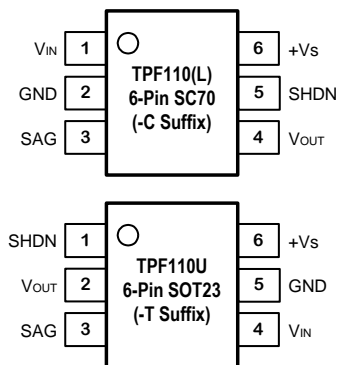

Pin	Pin Name	Function
1	V <sub>IN</sub>	Input Voltage.
2	GND	Ground.
3	SAG	Feedback Connection.
4	V <sub>OUT</sub>	Output Voltage.
5	SHDN	Shut-down.
6	+V <sub>S</sub>	Positive Power Supply.

**Absolute Maximum Ratings<sup>Note</sup>**

Parameters		Value	Unit
Power Supply, V <sub>DD</sub> to GND		6.0	V
PD	Power Dissipation, T <sub>A</sub> = 25°C, 6-Lead SC70	300	mW
V <sub>IN</sub>	Input Voltage	V <sub>DD</sub> + 0.3V to GND - 0.3V	
I <sub>OUT</sub>	Output Current	65	mA
T <sub>J</sub>	Maximum Junction Temperature	150	°C
T <sub>A</sub>	Operating Temperature Range	-45 to 85	°C
T <sub>STG</sub>	Storage Temperature Range	-65 to 150	°C
TL	Lead Temperature (Soldering, 10 sec)	300	°C
θ <sub>JA</sub>	6-Lead SC70	430	°C/W

(1) This data was taken with the JEDEC low effective thermal conductivity test board.

(2) This data was taken with the JEDEC standard multilayer test boards.

\* **Note:** Stresses beyond those listed under Absolute Maximum Ratings may cause permanent damage to the device. Exposure to any Absolute Maximum Rating condition for extended periods may affect device reliability and lifetime.

**ESD, Electrostatic Discharge Protection**

Symbol	Parameter	Condition	Minimum Level	Unit
HBM	Human Body Model ESD	MIL-STD-883H Method 3015.8	8	kV
CDM	Charged Device Model ESD	JEDEC-EIA/JESD22-C101E	2	kV

**TPF110/TPF110U/TPF110L**  
**Ultra-low Power Video Filter with Shut-down & SAG Correction**

**Electrical Characteristics** All test condition is  $V_{DD} = 3.3V$ ,  $T_A = +25^{\circ}C$ ,  $R_L = 150\Omega$  to GND, unless otherwise noted.

SYMBOL	PARAMETER	CONDITIONS	MIN	TYP	MAX	UNITS
<b>Input Electrical Specifications</b>						
$V_{DD}$	Supply Voltage Range		2.85		5.5	V
$I_{DD(ON)}$	Quiescent Current ( $I_Q$ ) <sup>(1)</sup>	TPF110: $V_{DD}=3.3V$ , $V_{IN}=500mV$ , $EN=V_{DD}$ , no load		3.9	4.9	mA
		TPF110: $V_{DD}=5.0V$ , $V_{IN}=500mV$ , $EN=V_{DD}$ , no load		5.1	6.3	mA
		TPF110L: $V_{DD}=3.3V$ , $V_{IN}=500mV$ , $EN=V_{DD}$ , no load		1.9	2.8	mA
		TPF110L: $V_{DD}=5.0V$ , $V_{IN}=500mV$ , $EN=V_{DD}$ , no load		2.9	3.9	mA
$I_{DD(OFF)}$	Disabled Current	$V_{DD}=3.3V$ , $EN=0$		0.5	1.5	$\mu A$
		$V_{DD}=5.0V$ , $EN=0$		1.5	3	$\mu A$
$V_{OLS}$	Output Level Shift Voltage	$V_{IN} = 0V$ , no load, input referred	53	80	124	mV
$V_{CLAMP}$	Input Voltage Clamp	$I_{IN} = -100\mu A$	-40	0	+40	mV
$I_{CLAMP-CHG}$	Clamp Charge Current	$V_{IN} = V_{CLAMP} - 200mV$	-1.5	-1.7		mA
$I_{CLAMP-DCHG}$	Clamp Discharge Current	$V_{IN} = 500mV$	1.5	2.0	5.1	$\mu A$
$R_{IN}$	Input Impedance	$0.5V < V_{IN} < 1.0V$	0.5	3		M $\Omega$
AV	Voltage Gain	$V_{IN}=0.5V, 1V$ and $2V$ $R_L = 150\Omega$ to GND	5.9	6.01	6.025	dB
$A_{SAG}$	SAG Correction DC Gain to $V_{OUT}$	SAG open		2.25		V/V
PSRR	Power Supply Rejection Ratio	$\Delta V_{DD} = 3.3V$ to $3.6V$		61		dB
		$\Delta V_{DD} = 5.0V$ to $5.5V$ , $50Hz$ , $V_{IN}=0.7V$		67		dB
$V_{OH}$	Output Voltage High Swing	$V_{IN} = 3V$ , $R_L = 150\Omega$ to GND		3.18		V
$V_{OL}$	Output Voltage Low Swing	$V_{IN} = -0.3V$ , $R_L = 75\Omega$		0.05		V
$I_{SC}$	Short-circuit current	$V_{IN}=2V$ , output to GND through $10\Omega$	65			mA
		$V_{IN}=100mV$ , output short to $V_{DD}$	65			mA
$V_{IL}$	Disable Threshold	$V_{DD} = 3.0V$ to $5.5V$			0.8	V
$V_{IH}$	Enable Threshold	$V_{DD} = 3.0V$ to $5.5V$	1.6			V
$R_{OUT}$	Output Impedance	$EN = 0V$ DC		12		k $\Omega$
		$EN = 0V$ , $f = 4.5MHz$		5.8		k $\Omega$

Note: (1). 100% tested at  $T_A=25^{\circ}C$ .

**TPF110/TPF110U/TPF110L**
**Ultra-low Power Video Filter with Shut-down & SAG Correction**

SYMBOL	PARAMETER	CONDITIONS	MIN	TYP	MAX	UNITS
<b>AC Electrical Specifications</b>						
f <sub>-1dB</sub>	-1dB Bandwidth <sup>(2)</sup>	R <sub>L</sub> =150Ω	7.6	8.2	9.1	MHz
f <sub>-3dB</sub>	-3dB Bandwidth <sup>(2)</sup>	R <sub>L</sub> =150Ω	7.8	9	10.5	MHz
Att <sub>27MHz</sub>	Stop Band Attenuation <sup>(2)</sup>	f = 27MHz	38.2	57.2	73.6	dB
SR	Slew Rate	2V output step, 80% to 20%		38		V/μs
dG	Differential Gain	Video input range 1V		0.4	1.2	%
dP	Differential Phase	Video input range 1V		0.7	1.5	°
THD	Total Harmonic Distortion	TPF110: f=1MHz, V <sub>OUT</sub> =1.4V <sub>PP</sub>	0.03	0.1	0.2	%
		TPF110L: f=1MHz, V <sub>OUT</sub> =1.4V <sub>PP</sub>		0.2		%
D/DT	Group Delay Variation	f = 100kHz, 5MHz		5.4		ns
t <sub>PD</sub>	Propagation Delay	Maximum delay from input to output: 100kHz to 4.43MHz	54	80.7	127	ns
	Input-to-Output Isolation (Disabled)	f = 1MHz, V <sub>IN</sub> =0.7V <sub>PP</sub>	-89	-96		dB
SNR	Signal-to-Noise Ration	f= 100kHz to 4.43MHz	65	68		dB
t <sub>ON</sub>	Enable Time	V <sub>IN</sub> = 500mV, V <sub>OUT</sub> to 1%		1000		ns
t <sub>OFF</sub>	Disable Time	V <sub>IN</sub> = 500mV, V <sub>OUT</sub> to 1%		45		ns
CLG	Chroma-Luma-Gain <sup>(2)</sup>	400kHz to 3.58MHz and 4.43MHz		0.18	0.8	dB
CLD	Chroma-Luma-Delay	400kHz to 3.58MHz and 4.43MHz		9.2	31	ns
t <sub>F</sub>	Falling Time	2.5V <sub>STEP</sub> , 80% - 20%		25		ns
t <sub>R</sub>	Rising Time	2.5V <sub>STEP</sub> , 20% - 80%		22		ns

**Note: (2). Guaranteed by design.**

**Typical Performance Characteristics** All test condition is  $V_{DD} = 3.3V$ ,  $T_A = +25^{\circ}C$ ,  $R_L = 150\Omega$  to GND, unless otherwise noted.

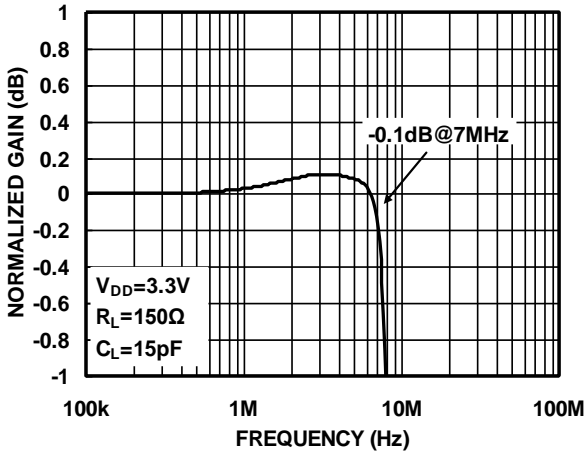

Figure1. Small-Scale Frequency Response

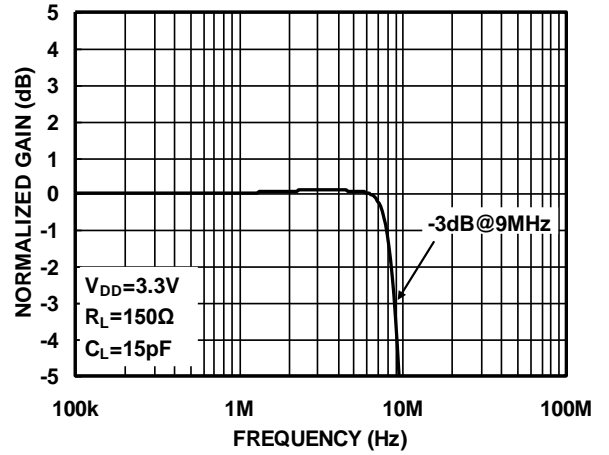

Figure2. Large-Scale Frequency Response

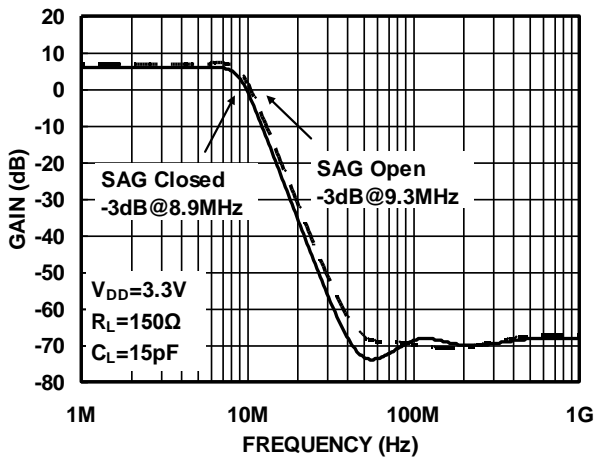

Figure3. Gain Vs. Frequency

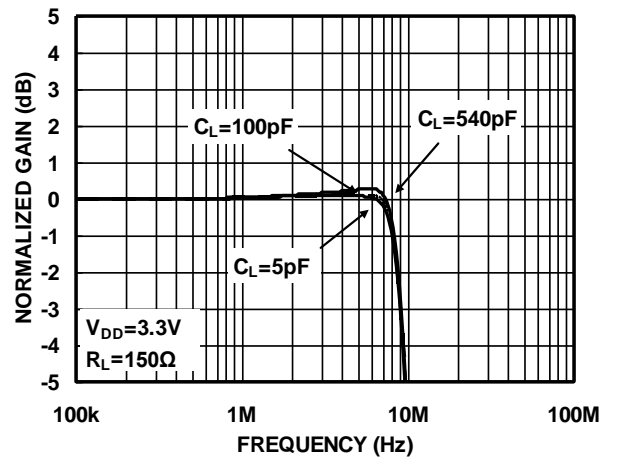

Figure4. Gain Vs. Frequency With  $C_{LOAD}$

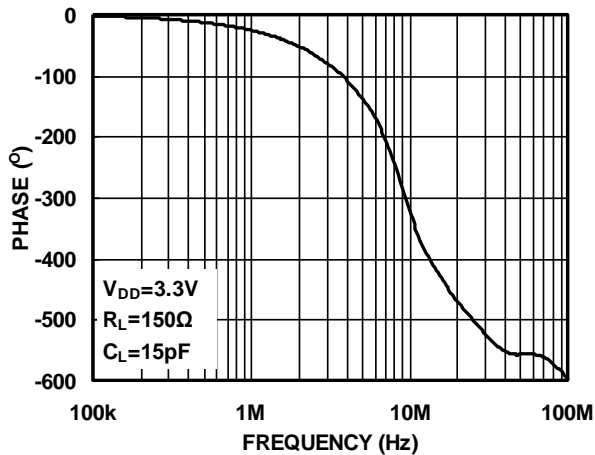

Figure5. Phase Vs. Frequency

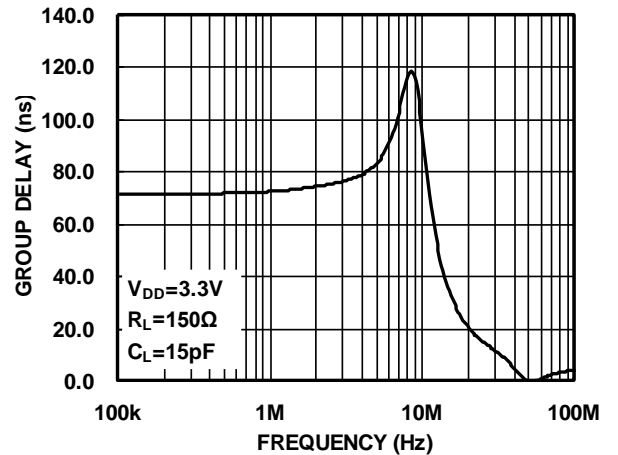

Figure6. Group Delay vs Frequency

**TPF110/TPF110U/TPF110L**  
**Ultra-low Power Video Filter with Shut-down & SAG Correction**

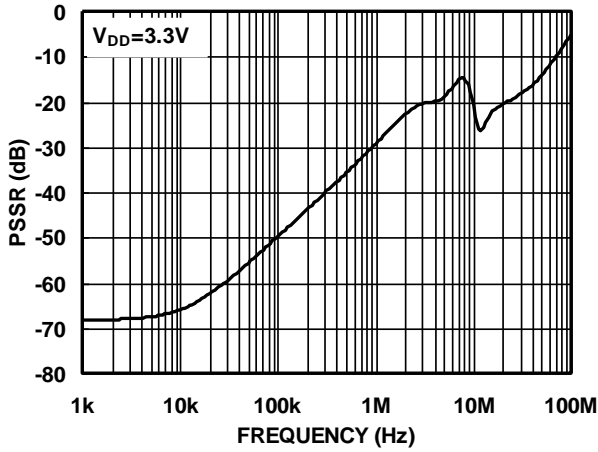

Figure7. PSRR Vs. Frequency

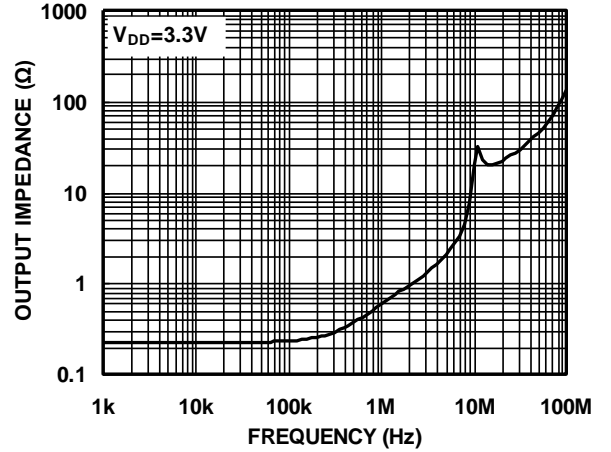

Figure8. Output Impedance Vs. Frequency

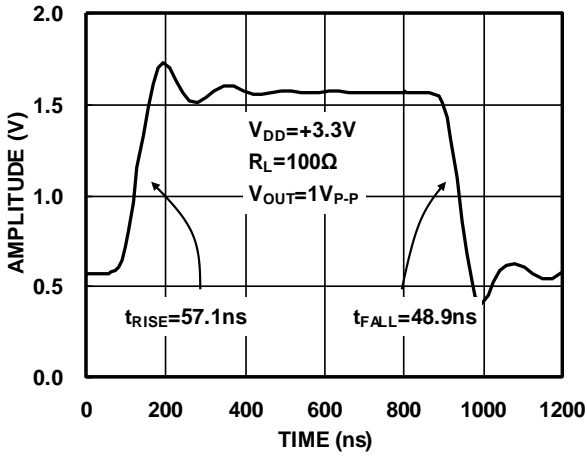

Figure9. Large-Signal Pulse Response Vs. Time

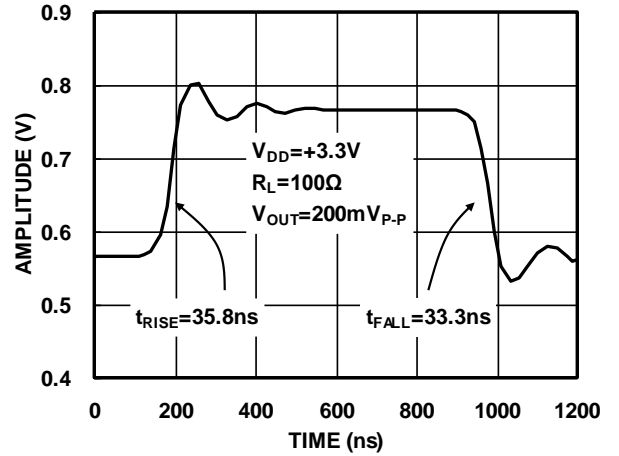

Figure10. Large-Signal Pulse Response Vs. Time

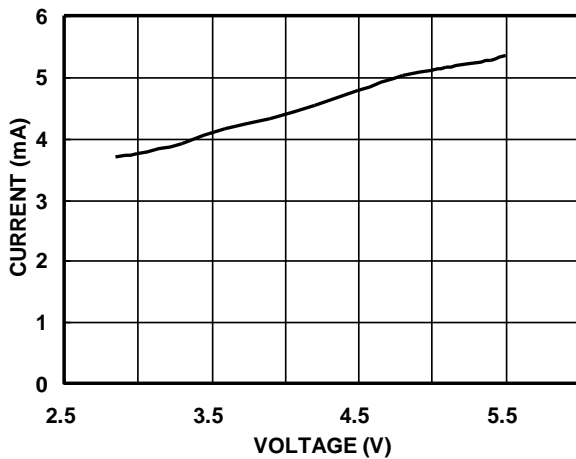

Figure11. Quiescent Current Vs. Power Supply Voltage

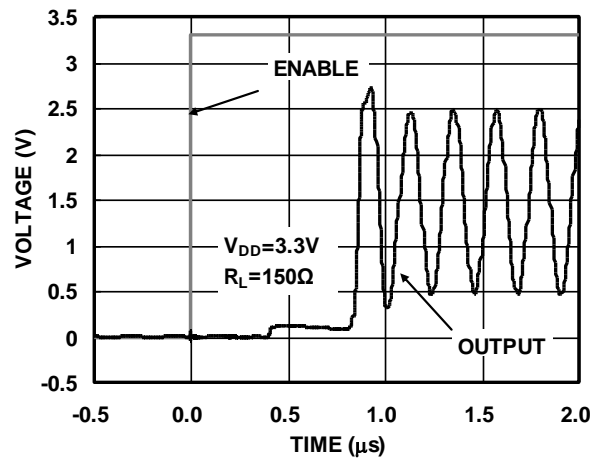

Figure12. Enable Response Time

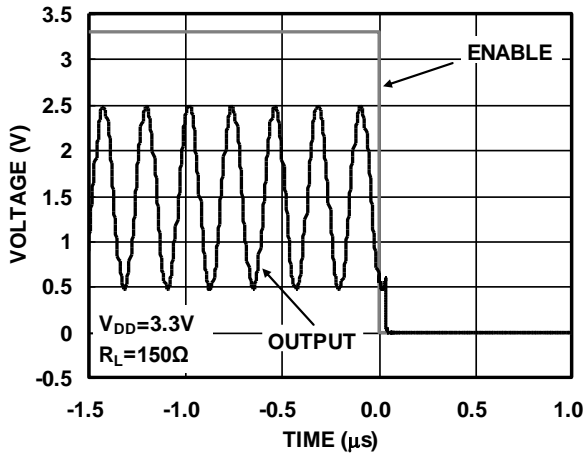

Figure13. Disable Response Time

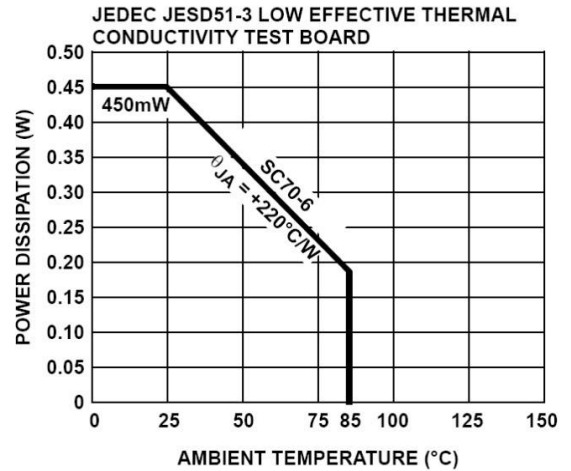

Figure14. Package Power Dissipation Vs. Ambient Temperature

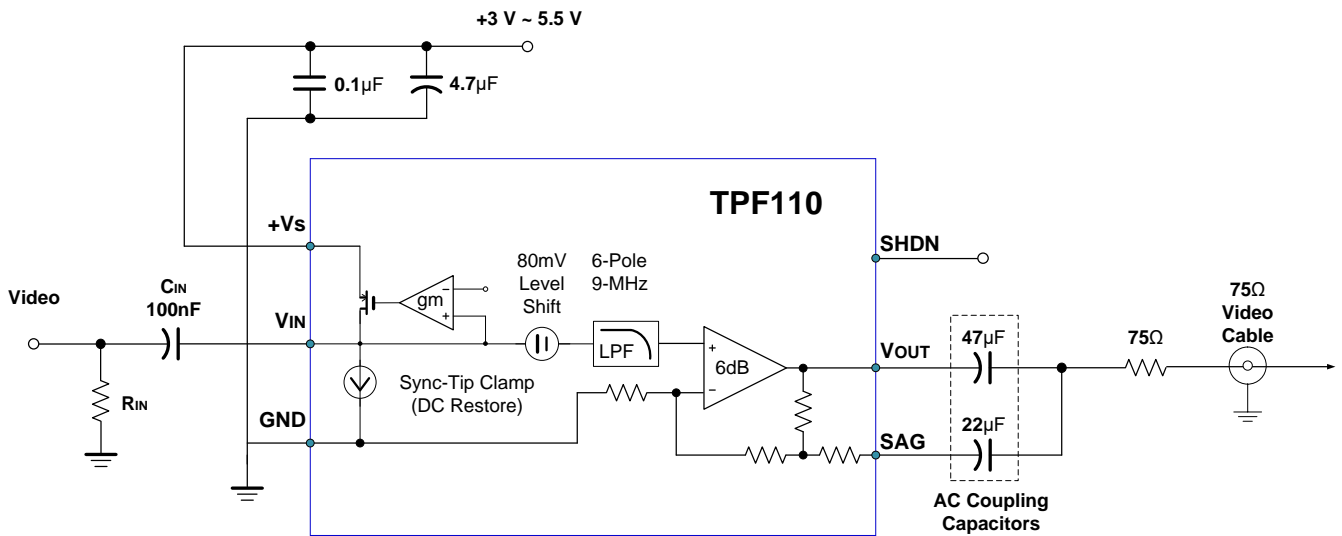

Figure15. Typical Application

## Application Information

The TPF110/TPF110L is a single supply rail-to-rail output amplifier achieving a -3dB bandwidth of around 9MHz and slew rate of about 38V/μs while demanding only 3.85mA of supply current. This part is ideally suited for applications with specific micro power consumption and high bandwidth demands. As the performance characteristics above and the features described below, the TPF110/TPF110L is designed to be very attractive for portable composite video applications.

The TP110/TP110L features a sync clamp, low pass function, and SAG network at the output facilitating

reduction of typically large AC coupling capacitors. See Figure 15.

## Internal Sync Clamp

The typical embedded video DAC operates from a ground referenced single supply. This becomes an issue because the lower level of the sync pulse output may be at a 0V reference level to some positive level. The problem is presenting a 0V input to most single supply driven amplifiers will saturate the output stage of the amplifier resulting in a clipped sync tip and degrading the video image. A larger positive reference

may offset the input above its positive range.

The TPF110/TPF110L features an internal sync clamp and offset function to level shift the entire video signal to the best level before it reaches the input of the amplifier stage. These features are also helpful to avoid saturation of the output stage of the amplifier by setting the signal closer to the best voltage range.

The simplified block diagram of the TPF110/TPF110L in Page-1. The AC coupled video sync signal is pulled negative by a current source at the input of the comparator amplifier. When the sync tip goes below the comparator threshold the output comparator is driven negative, The PMOS device turns on clamping sync tip to near ground level. The network triggers on the sync tip of video signal.

### Low Pass Filter--Sallen Key

The Sallen Key is a classic low pass configuration. This provides a very stable low pass function, and in the case of the TPF110/TPF110L, a six-pole roll-off at around 9MHz. The six-pole function is accomplished with an RC low pass network placed in series with and before the Sallen Key.

### Output Couple

TPF110/TPF110L output could support both “AC Couple” and “DC Couple”, if use “AC Couple”, this capacitor is typically between 220-μF and 1000-μF, although 470-μF is common. This value of this capacitor must be this large to minimize the line tilt (droop) and/or field tilt associated with ac-coupling as described previously in this document.

The TPF110/TPF110L internal sync clamp makes it possible to DC couple the output to a video load, eliminating the need for any AC coupling capacitors, thereby saving board space and additional expense for capacitors. This makes the TPF110/TPF110L extremely attractive for portable video applications. Additionally, this solution completely eliminates the issue of field tilt in the lower frequency. The trade off is greater demand of supply current. Typical load current for AC coupled is around 1mA, compared to typical 6.6mA used when DC coupling.

### Output Drive Capability and Power Dissipation

With the high output drive capability of the TPF110/TPF110L, it is possible to exceed the +125°C absolute maximum junction temperature under certain load current conditions. Therefore, it is important to calculate the maximum junction temperature for an application to determine if load conditions or package types need to be modified to assure operation of the amplifier in a safe operating area. The maximum power dissipation allowed in a package is determined according to Equation:

$$PD_{MAX} = \frac{T_{JMAX} - T_{AMAX}}{\theta_{JA}}$$

Where:

$T_{JMAX}$  = Maximum junction temperature

$T_{AMAX}$  = Maximum ambient temperature

$\theta_{JA}$  = Thermal resistance of the package

The maximum power dissipation actually produced by an IC is the total quiescent supply current times the total power supply voltage, plus the power in the IC due to the load, or: for sourcing:

$$PD_{MAX} = V_s \times I_{SMAX} + (V_s - V_{OUT}) \times \frac{V_{OUT}}{R_L}$$

Where:

$V_s$  = Supply voltage

$I_{SMAX}$  = Maximum quiescent supply current

$V_{OUT}$  = Maximum output voltage of the application

$R_{LOAD}$  = Load resistance tied to ground

By setting the two PD<sub>MAX</sub> equations equal to each other, we can solve the output current and R<sub>LOAD</sub> to avoid the device overheat.

### Power Supply Bypassing Printed Circuit Board Layout

As with any modern operational amplifier, a good printed circuit board layout is necessary for optimum performance. Lead lengths should be as short as possible. The power supply pin must be well bypassed to reduce the risk of oscillation. For normal single supply operation, a single 4.7μF tantalum capacitor in parallel with a 0.1μF ceramic capacitor from VS+ to GND will suffice.



## VIDEO FILTER DRIVER SELECTION GUIDE

P/N	Product Description	Channel	-3dB Bandwidth	Package
TPF111	Low power, 1 channel 6 <sup>th</sup> order 9MHz	1-SD	9MHz	SC70-5 SO-8
TPF113	Low power 3 channel, 6th-order 9MHz SD video filter	3-SD	9MHz	SO-8
TPF114	Low power 4 channel, 6th-order 9MHz SD video filter	4-SD	9MHz	MSOP-10 TSSOP-14
TPF116	Low power 4 channel, 6th-order 9MHz SD video filter for CVBS, SVIDEO	6-SD	9MHz	TSSOP-14
TPF123	3 channel 6th-order 13.5MHz, 960H/720H-CVBS video filter or Y'Pb'Pr 480P/576P video filter	3-ED	13.5MHz	SO-8
TPF133	Low power 3 channel, 6th-order 36MHz HD video filter	3-HD	36MHz	SO-8
TPF134	Low power 3 channel, 6th-order 36MHz HD video filter and 1 channel SD video filter	1-SD& 3-SD	9MHz 36MHz	MSOP-10 TSSOP-14
TPF136	Low power 3 channel, 6th-order 36MHz HD video filter and 3 channel SD video filter	3-SD& 3-HD	9MHz 36MHz	TSSOP-20
TPF143	Low power 3 channel, 6th-order 72MHz Full HD video filter	3-FHD	72MHz	SO-8
TPF144	Low power 3 channel, 6th-order 72MHz Full HD video filter and 1 channel SD video filter	1-SD& 3-FHD	9MHz 72MHz	MSOP-10 TSSOP-14
TPF146	Low power 3 channel, 6th-order 72MHz Full HD video filter and 3 channel SD video filter	3-SD& 3-FHD	9MHz 72MHz	TSSOP-20
TPF153	Low power 3 channel, 6th-order 220MHz Full HD video filter	3-CH	220MHz	SO-8

**Package Outline Dimensions**

**Small Outline Transistor Plastic Packages (SC70-6)**

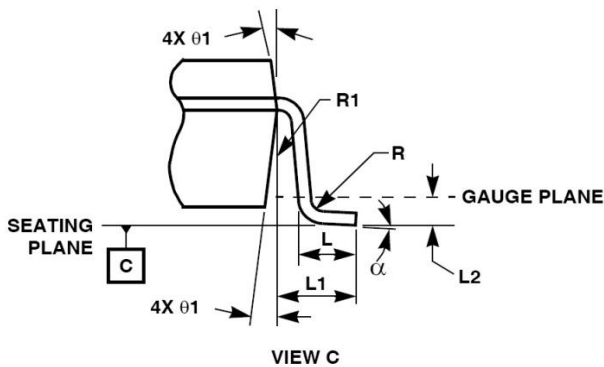
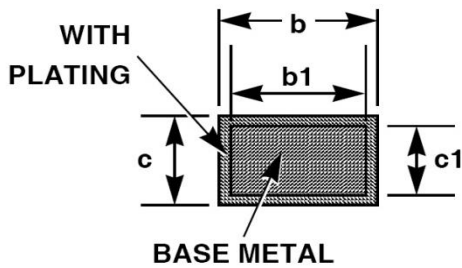
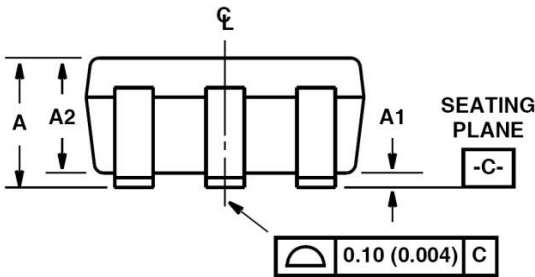
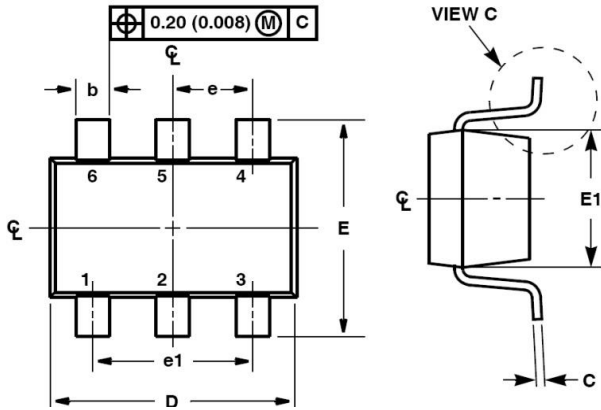

**6 LEAD OUTLINE TRANSISTOR PLASTIC PACKAGE**

SYMBOL	INCHES		MILLIMETERS		NOTES
	MIN	MAX	MIN	MAX	
A	0.031	0.039	0.80	1.00	-
A1	0.001	0.004	0.025	0.10	-
A2	0.034	0.036	0.85	0.90	-
b	0.006	0.012	0.15	0.30	-
b1	0.006	0.010	0.15	0.25	-
c	0.004	0.008	0.10	0.20	6
c1	0.004	0.006	0.10	0.15	6
D	0.073	0.085	1.85	2.15	3
E	0.084BSC		2.1 BSC		-
E1	0.045	0.053	1.15	1.35	3
e	0.0256Ref		0.65 Ref		-
e1	0.0512Ref		1.30 Ref		-
L	0.010	0.018	0.26	0.46	4
L1	0.016 Ref		0.40 Ref		-
L2	0.006 BSC		0.15 BSC		-
N	6		6		5
R	0.04	-	0.10	-	-
α	0°	8°	0°	8°	-

NOTES:

1. Dimensioning and tolerance per ASME Y14.5M-1994.
2. Package conforms to EIAJ SC70 and JEDEC MO203AB.
3. Dimensions D and E1 are exclusive of mold flash, protrusions, or gate burrs.
4. Footlength L measured at reference to gauge plane.
5. "N" is the number of terminal positions.
6. These Dimensions apply to the flat section of the lead between 0.08mm and 0.15mm from the lead tip.
7. Controlling dimension: MILLIMETER. Converted inch dimensions are for reference only

## **IMPORTANT NOTICE AND DISCLAIMER**

**Copyright**© 3PEAK 2012-2023. All rights reserved.

**Trademarks.** Any of the 思瑞浦 or 3PEAK trade names, trademarks, graphic marks, and domain names contained in this document /material are the property of 3PEAK. You may NOT reproduce, modify, publish, transmit or distribute any Trademark without the prior written consent of 3PEAK.

**Performance Information.** Performance tests or performance range contained in this document/material are either results of design simulation or actual tests conducted under designated testing environment. Any variation in testing environment or simulation environment, including but not limited to testing method, testing process or testing temperature, may affect actual performance of the product.

**Disclaimer.** 3PEAK provides technical and reliability data (including data sheets), design resources (including reference designs), application or other design recommendations, networking tools, security information and other resources "As Is". 3PEAK makes no warranty as to the absence of defects, and makes no warranties of any kind, express or implied, including without limitation, implied warranties as to merchantability, fitness for a particular purpose or non-infringement of any third-party's intellectual property rights. Unless otherwise specified in writing, products supplied by 3PEAK are not designed to be used in any life-threatening scenarios, including critical medical applications, automotive safety-critical systems, aviation, aerospace, or any situations where failure could result in bodily harm, loss of life, or significant property damage. 3PEAK disclaims all liability for any such unauthorized use.