

Features

- Analog Switch Voltage: 3.3V, 5V, 10V
- Low ON-State Resistance:
 - typical 50Ω at Vs = 9V
 - typical 60Ω at Vs = 4.5V
 - typical 300Ω at Vs = 3V
- Bandwidth: 200 MHz
- Fast switching times: t_{ON} = 60ns, t_{OFF} = 50ns
- Break-Before-Make Switching
- Operation Temperature Range: -40°C to 125°C

Applications

- Industry control systems
- Battery-powered systems
- Audio Signal Routing
- Instrumentation

Description

The TPW4054 is a single-pole four-throw analog switch (SP4T) suitable for use in analog or digital 4:1 multiplexer/demultiplexer applications. The switch features two digital select inputs (S0, S1), four independent inputs/outputs (An), a common input/output (A) and a digital enable input (/E). When /E is HIGH, the switches are turned off.

The device is designed on an enhanced process that provides lower power dissipation yet gives high switching speeds. These devices can operate equally well as either multiplexers or demultiplexers and have an input range that extends to the supplies. All channels exhibit break-before-make switching action, preventing momentary shorting when switching channels.

Switch Selection Guide

Product	Switch Configuration	Supply Voltage(V)	Ron(OHM)	Bandwidth(MHz)	Package
TPW4051	8:1	12	50	200	SOIC-16, TSSOP-16, QFN-16
TPW4052	(4:1)*2	12	50	200	SOIC-16, TSSOP-16
TPW4053	(2:1)*3	12	50	200	SOIC-16, TSSOP-16
TPW4054	4:1	12	50	200	MSOP-10
TPW4066	(1:1)*4	12	50	200	SOP-14, TSSOP-14
TPW3111	1:1	5.5	1	100	SC70-5
TPW3115	1:1	5.5	5	250	SC70-5, SOT23-5
TPW4157	2:1	5.5	1	100	SC70-6
TPW3157A	2:1	5.5	2	100	SC70-6
TPW3221	(2:1)*2	5.5	1	100	MSOP-10
TPW3223	(2:1)*2	5.5	1	100	QFN-10, 1.4*1.8mm

Table of Contents

Features	1
Applications	1
Description	1
Switch Selection Guide	1
Table of Contents	2
Revision History	3
Order Information	3
Pin Configuration, Description and Functional Table ^{Note 1}	4
TPW4054	4
Absolute Maximum Ratings ^{Note 1}	5
ESD Rating	5
Thermal Information	5
Recommended Operating Conditions ^{Note 1}	5
Electrical Characteristics	6
Single Supply, $V_{CC} = 4.5$ to $5.5V$, $GND = 0V$, unless otherwise noted	6
Single Supply, $V_{CC} = 3$ to $3.6V$, $GND = 0V$, unless otherwise noted	7
Single Supply, $V_{CC} = 9V$ to $11V$, $GND = 0V$, unless otherwise noted	8
Typical Performance Characteristics	9
Test Circuit and Waveforms	10
Application Information	11
Tape and Reel Information	12
Package Outline Dimensions	13
MSOP-10	13
IMPORTANT NOTICE AND DISCLAIMER	14

Revision History

Date	Revision	Notes
2019/12/25	Rev.Pre	Pre-release version
2020/3/31	Rev.A	Initial version

Order Information

Order Number	Operating Temperature Range	Package	Marking Information	MSL	Transport Media, Quantity
TPW4054-VR	-40 to 125°C	10-Pin MSOP	W4054	3	Tape and Reel, 3000

Pin Configuration, Description and Functional Table ^{Note 1}

TPW4054

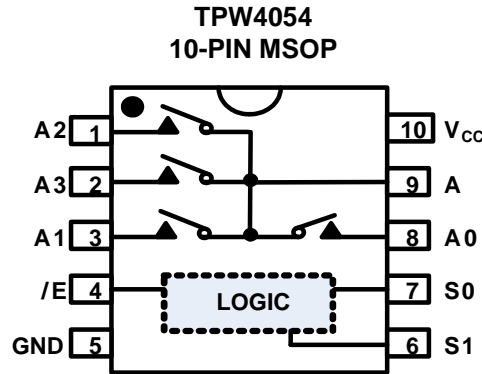

Pin Description

Pin No.	Pin Name	Input / Output	Description	Pin No.	Pin Name	Input / Output	Description
1	A2	Input / Output	Channel 2 input or output	6	S1	Input	Control Input
2	A3	Input / Output	Channel 3 input or output	7	S0	Input	Control Input
3	A1	Input / Output	Channel 1 input or output	8	A0	Input / Output	Channel 0 input or output
4	/E	Input	Enable switches, active low	9	A	Input / Output	Common input or output
5	GND		Ground	10	V _{CC}		Power Input

Functional Table

/E, Enable	S1	S0	ON Channel
L	L	L	A0
L	L	H	A1
L	H	L	A2
L	H	H	A3
H	X	X	None

X = Don't care, NA = Not Available

Absolute Maximum Ratings Note 1

Parameters	Rating
Supply Voltage, V_{CC} - GND	-0.5V to 13V
Analog Switch Voltage	- 0.5V to $V_{CC} + 0.5V$
Analog Switch Current	$\pm 25mA$
Analog Switch Diode Current	$\pm 20mA$
Digital Input Voltage, /E, S2, S1, S0	GND to $V_{CC} + 0.5V$
Digital Input Diode Current	$\pm 20mA$
Maximum Junction Temperature	150°C
Storage Temperature Range	-65 to 150°C
Lead Temperature (Soldering, 10 sec)	260°C

Note 1: Stresses beyond those listed under Absolute Maximum Ratings may cause permanent damage to the device. Exposure to any Absolute Maximum Rating condition for extended periods may affect device reliability and lifetime.

ESD Rating

Symbol	Parameter	Condition	Minimum Level	Unit
HBM	Human Body Model ESD	ANSI/ESDA/JEDEC JS-001	1	kV
CDM	Charged Device Model ESD	ANSI/ESDA/JEDEC JS-002	1	kV

Thermal Information

Package Type	θ_{JA}	θ_{JC}	Unit
16-Pin SOIC	100	50	°C/W
16-Pin TSSOP	150	60	°C/W

Recommended Operating Conditions Note 1

Over operating temperature range

Parameters	Min	Max	Unit
Supply Voltage, V_{CC}	3	12	V
Select Input Voltage	0	V_{CC}	V
Input Transition Rise and Fall Rate		100	ns/V
Switch I/O Port Voltage	GND	V_{CC}	V
Operating Temperature Range	-40	125	°C

Note 1: Select input must be held HIGH or LOW and it must not float.

Electrical Characteristics

Single Supply, $V_{CC} = 4.5$ to $5.5V$, $GND = 0V$, unless otherwise noted.

Symbol	Parameter	Conditions	V_{CC} (V)	25°C	-40°C to 85°C	-40°C to 125°C	Limit	Unit
Power Supply								
I_{CC}	Quiescent Supply Current	$V_{IN} = 0V$ or V_{CC}	5.5	4	6	8	Max	μA
Digital Input								
V_{IH}	Input Voltage High				2.0	2.0	Min	V
V_{IL}	Input Voltage Low				0.8	0.8	Max	V
I_{IN}	Control Input Leakage	$V_{IN} = 0V$ or V_{CC}	5.5	± 0.4	± 1	± 1	Max	μA
Analog Switch								
R_{ON}		$I_{OUT} = 1mA$, $V_{IS} = GND$ or V_{CC}	4.5	60			Typ	Ω
R_{ON}		$I_{OUT} = 1mA$, $V_{IS} = GND$ or V_{CC}	4.5	100	130	150	Max	Ω
ΔR_{ON}	On Resistance Match between Channels	$I_{OUT} = 1mA$, $V_{IS} = 2.5V$	4.5	20	30	35	Max	Ω
$R_{FLAT(ON)}$	On Resistance Flatness	$I_{OUT} = 1mA$	4.5	60	80	80	Max	Ω
$I_{CH(OFF)}$	Switch OFF Leakage Current on Channel	$V_{IS} = GND$, $V_{OS} = V_{CC}$; or $V_{IS} = V_{CC}$, $V_{OS} = GND$	5.5	± 0.4	± 1	± 1	Max	μA
$I_{COM(OFF)}$	Switch OFF Leakage Current on Common	$V_{IS} = GND$, $V_{OS} = V_{CC}$; or $V_{IS} = V_{CC}$, $V_{OS} = GND$,	5.5	± 0.4	± 2	± 2	Max	μA
$I_{(ON)}$	Switch ON Leakage Current	$V_{IS} = GND$ or V_{CC}	5.5	± 0.4	± 2	± 2	Max	μA
Dynamic Characteristics								
t_{PHL} , t_{PLH}	Switch IN to OUT time	$C_L = 50pF$	4.5	5			Typ	ns
t_{ON}	Switch turn-on time	$C_L = 50pF$	4.5	60			Max	ns
t_{OFF}	Switch turn-off time	$C_L = 50pF$	4.5	50			Max	ns
	OFF-Isolation	$f = 1MHz$, $R_L = 50\Omega$, $C_L = 10pF$	5	-70			Typ	dB
	Crosstalk in channel	$f = 1MHz$, $R_L = 50\Omega$, $C_L = 10pF$	5	-70			Typ	dB
	Crosstalk in control	Between control and any switch; $R_L = 600\Omega$; $f = 1MHz$; E or Sn square wave between V_{CC} and GND	5	110			Typ	mV
BW	Bandwidth	$R_L = 50\Omega$	5	200			Typ	MHz
THD	Total Harmonic Distortion	$R_L = 10k\Omega$, $f = 1kHz$	5	0.05			Typ	%
Capacitance								
C_{IN}	Switch Input Capacitance		5	5			Typ	pF
C_{COM}	Common Output Capacitance		5	12			Typ	pF
C_{PD}	Power Dissipation Capacitance		5	50			Typ	pF

Single Supply, $V_{CC} = 3$ to $3.6V$, $GND = 0V$, unless otherwise noted.

Symbol	Parameter	Conditions	V_{CC} (V)	25°C	-40°C to 85°C	-40°C to 125°C	Limit	Unit
Power Supply								
I_{CC}	Quiescent Supply Current	$V_{IN} = 0V$ or V_{CC}	3.6	4	6	8	Max	μA
Digital Input								
V_{IH}	Input Voltage High				2.0	2.0	Min	V
V_{IL}	Input Voltage Low				0.8	0.8	Max	V
I_{IN}	Control Input Leakage	$V_{IN} = 0V$ or V_{CC}	3.6		± 1	± 1	Max	μA
Analog Switch								
R_{ON}		$I_{OUT} = 1mA$, $V_{IS} = GND$ or V_{CC}	3	300			Typ	Ω
$R_{FLAT(ON)}$	On Resistance Flatness	$I_{OUT} = 1mA$	3	100			Typ	Ω
$I_{CH(OFF)}$	Switch OFF Leakage Current on Channel	$V_{IS} = GND$, $V_{OS} = V_{CC}$; or $V_{IS} = V_{CC}$, $V_{OS} = GND$	3.6	± 0.4	± 1	± 1	Max	μA
$I_{COM(OFF)}$	Switch OFF Leakage Current on Common	$V_{IS} = GND$, $V_{OS} = V_{CC}$; or $V_{IS} = V_{CC}$, $V_{OS} = GND$,	3.6	± 0.4	± 2	± 2	Max	μA
$I_{(ON)}$	Switch ON Leakage Current	$V_{IS} = GND$ or V_{CC}	3.6	± 0.4	± 2	± 2	Max	μA
Dynamic Characteristics								
t_{PHL} , t_{PLH}	Switch IN to OUT time	$C_L = 50pF$	3	5			Typ	ns
t_{ON}	Switch turn-on time	$C_L = 50pF$	3	70			Max	ns
t_{OFF}	Switch turn-off time	$C_L = 50pF$	3	60			Max	ns
	OFF-Isolation	$f = 1MHz$, $R_L = 50\Omega$, $C_L = 10pF$	3.3	-70			Typ	dB
	Crosstalk	$f = 1MHz$, $R_L = 50\Omega$, $C_L = 10pF$	3.3	-70			Typ	dB
	Crosstalk in control	Between control and any switch; $R_L = 600\Omega$; $f = 1MHz$; E or Sn square wave between V_{CC} and GND	3.3	110			Typ	mV
BW	Bandwidth	$R_L = 50\Omega$	3.3	100			Typ	MHz
THD	Total Harmonic Distortion	$R_L = 10k\Omega$, $f = 1kHz$	3.3	0.2			Typ	%
Capacitance								
C_{IN}	Switch Input Capacitance		3.3	5			Typ	pF
C_{COM}	Common Output Capacitance		3.3	12			Typ	pF
C_{PD}	Power Dissipation Capacitance		3.3	50			Typ	pF

Single Supply, $V_{CC} = 9V$ to $11V$, $GND = 0V$, unless otherwise noted.

Symbol	Parameter	Conditions	V_{CC} (V)	25°C	-40°C to 85°C	-40°C to 125°C	Limit	Unit
Power Supply								
I_{CC}	Quiescent Supply Current	$V_{IN} = 0V$ or V_{CC}	9	8	12	16	Max	μA
Digital Input								
V_{IH}	Input Voltage High				2.4	2.4	Min	V
V_{IL}	Input Voltage Low				0.8	0.8	Max	V
I_{IN}	Control Input Leakage	$V_{IN} = 0V$ or V_{CC}	11	± 0.4	± 1	± 1	Max	μA
Analog Switch								
R_{ON}		$I_{OUT} = 1mA$, $V_{IS} = GND$ or V_{CC}	9	50			Typ	Ω
R_{ON}		$I_{OUT} = 1mA$, $V_{IS} = GND$ or V_{CC}	9	80	95	105	Max	Ω
ΔR_{ON}	On Resistance Match between Channels	$I_{OUT} = 1mA$, $V_{IS} = 1V$	9	15	25	30	Max	Ω
$R_{FLAT(ON)}$	On Resistance Flatness	$I_{OUT} = 1mA$	9	30	40	40	Max	Ω
$I_{CH(OFF)}$	Switch OFF Leakage Current on Channel	$V_{IS} = GND$, $V_{OS} = V_{CC}$; or $V_{IS} = V_{CC}$, $V_{OS} = GND$	11	± 0.4	± 1	± 1	Max	μA
$I_{COM(OFF)}$	Switch OFF Leakage Current on Common	$V_{IS} = GND$, $V_{OS} = V_{CC}$; or $V_{IS} = V_{CC}$, $V_{OS} = GND$,	11	± 0.4	± 2	± 2	Max	μA
$I_{(ON)}$	Switch ON Leakage Current	$V_{IS} = GND$ or V_{CC}	11	± 0.4	± 2	± 2	Max	μA
Dynamic Characteristics								
t_{PHL} , t_{PLH}	Switch IN to OUT time	$C_L = 50pF$	9	5			Typ	ns
t_{ON}	Switch turn-on time	$C_L = 50pF$	9	60			Max	ns
t_{OFF}	Switch turn-off time	$C_L = 50pF$	9	50			Max	ns
	OFF-Isolation	$f = 1MHz$, $R_L = 50\Omega$, $C_L = 10pF$	10	-70			Typ	dB
	Crosstalk	$f = 1MHz$, $R_L = 50\Omega$, $C_L = 10pF$	10	-70			Typ	dB
	Crosstalk in control	Between control and any switch; $R_L = 600\Omega$; $f = 1MHz$; E or Sn square wave between V_{CC} and GND	10	220			Typ	mV
BW	Bandwidth	$R_L = 50\Omega$	10	200			Typ	MHz
THD	Total Harmonic Distortion	$R_L = 10k\Omega$, $f = 1kHz$	10	0.03			Typ	%
Capacitance								
C_{IN}	Switch Input Capacitance		10	5			Typ	pF
C_{COM}	Common Output Capacitance		10	12			Typ	pF
C_{PD}	Power Dissipation Capacitance		10	50			Typ	pF

Typical Performance Characteristics

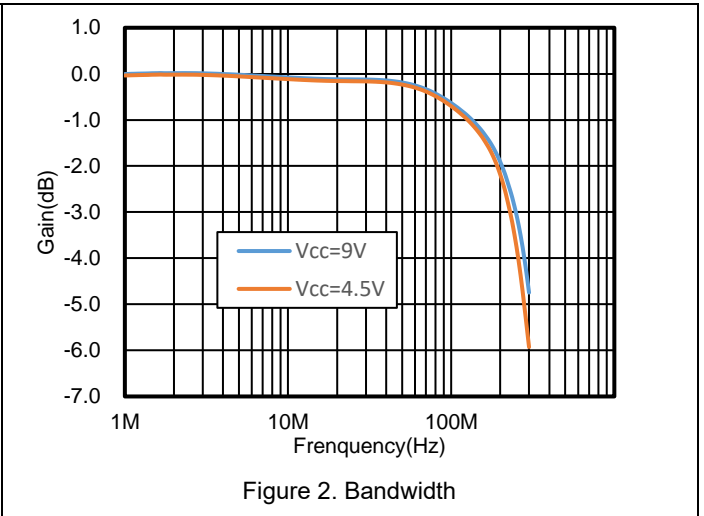
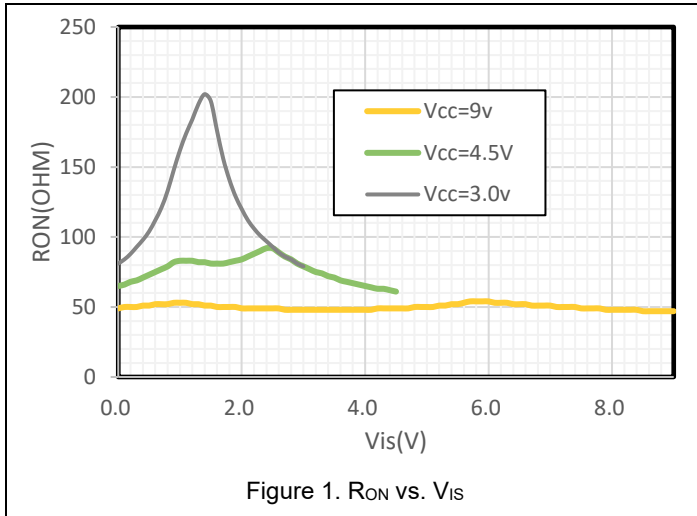

Test Circuit and Waveforms

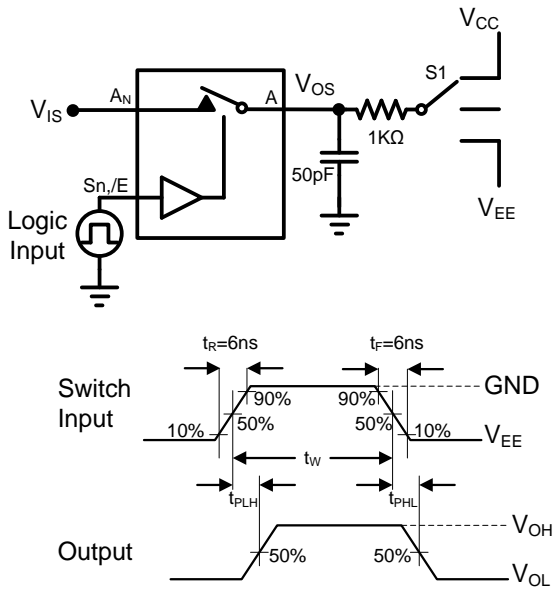

Parameter	Vis	S1 Position
t _{PHL} , t _{PLH}	Pulse	Open
t _{PZH} , t _{PHZ}	V _{CC}	V _{EE}
t _{PZL} , t _{PLZ}	V _{EE}	V _{CC}

t_{ON}: t_{PZH} OR t_{PZL}

t_{OFF}: t_{PHZ} OR t_{PLZ}

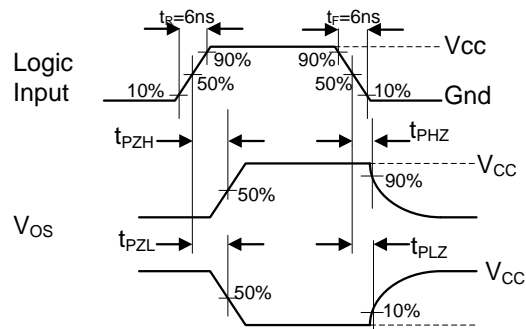

Figure 3 AC Test Circuit and Test Waveforms

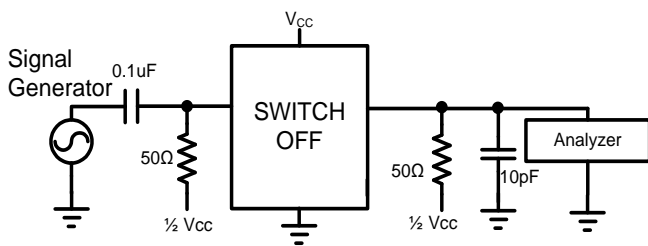

Figure 4 Off Isolation

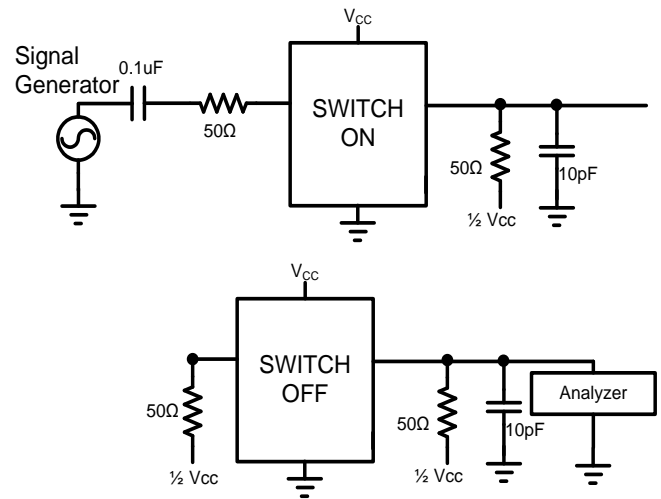
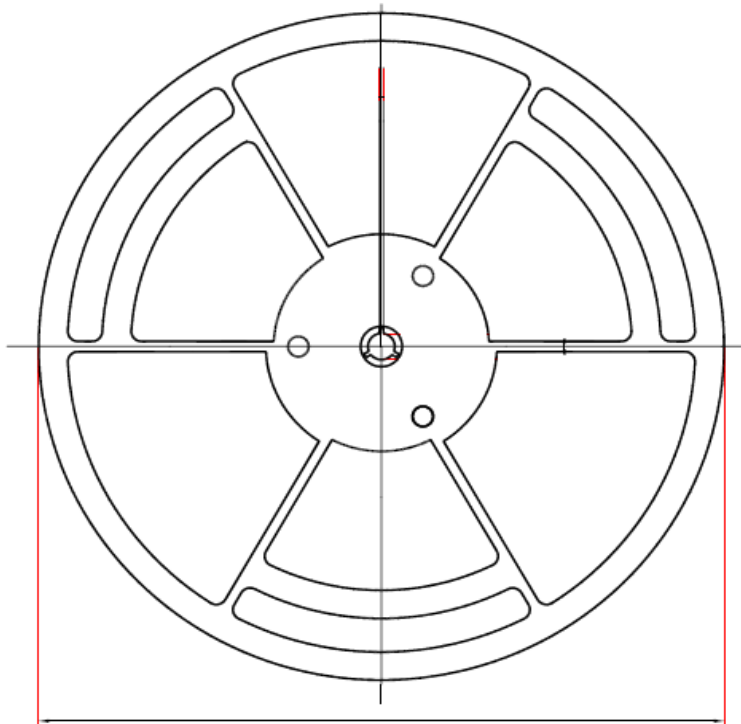

Figure 5 Crosstalk

Application Information

A 0.1- μ F bypass capacitor on V_{CC} and GND is recommended to prevent power disturbance.

Tape and Reel Information



D1: Reel Diameter

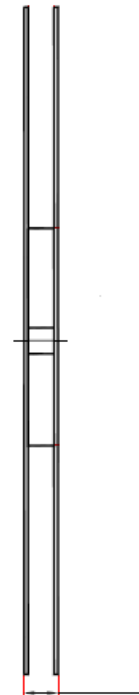

W1: Reel Width

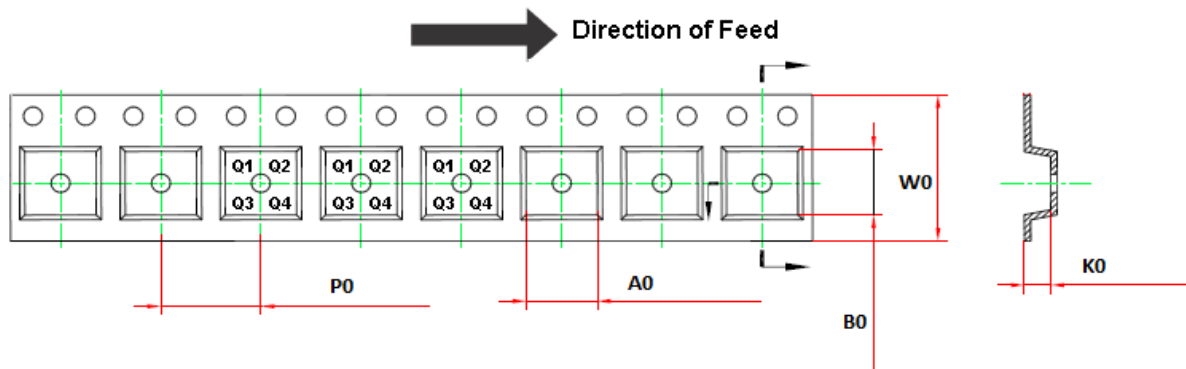

Order Number	Package	D1	W1	A0	B0	K0	P0	W0	Pin1 Quadrant
TPW4054-VR	10-Pin MSOP	330.0	17.6	5.2	3.3	1.5	8.0	12.0	Q1

Package Outline Dimensions

MSOP-10

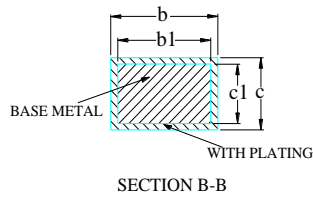
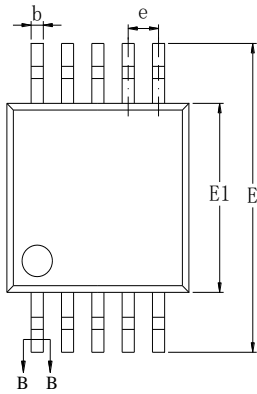
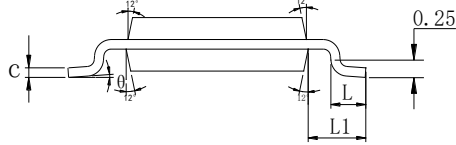
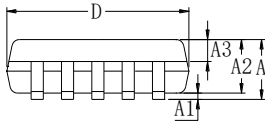

SYMBOL	MILLIMETER		
	MIN	NOM	MAX
A	—	—	1.10
A1	0.05	—	0.15
A2	0.75	0.85	0.95
A3	0.30	0.35	0.40
b	0.18	—	0.26
b1	0.17	0.20	0.23
c	0.15	—	0.19
c1	0.14	0.15	0.16
D	2.90	3.00	3.10
E	4.70	4.90	5.10
E1	2.90	3.00	3.10
e	0.50BSC		
L	0.40	—	0.70
L1	0.95REF		
θ	0	—	8°

IMPORTANT NOTICE AND DISCLAIMER

Copyright© 3PEAK 2012-2023. All rights reserved.

Trademarks. Any of the 思瑞浦 or 3PEAK trade names, trademarks, graphic marks, and domain names contained in this document /material are the property of 3PEAK. You may NOT reproduce, modify, publish, transmit or distribute any Trademark without the prior written consent of 3PEAK.

Performance Information. Performance tests or performance range contained in this document/material are either results of design simulation or actual tests conducted under designated testing environment. Any variation in testing environment or simulation environment, including but not limited to testing method, testing process or testing temperature, may affect actual performance of the product.

Disclaimer. 3PEAK provides technical and reliability data (including data sheets), design resources (including reference designs), application or other design recommendations, networking tools, security information and other resources "As Is". 3PEAK makes no warranty as to the absence of defects, and makes no warranties of any kind, express or implied, including without limitation, implied warranties as to merchantability, fitness for a particular purpose or non-infringement of any third-party's intellectual property rights. Unless otherwise specified in writing, products supplied by 3PEAK are not designed to be used in any life-threatening scenarios, including critical medical applications, automotive safety-critical systems, aviation, aerospace, or any situations where failure could result in bodily harm, loss of life, or significant property damage. 3PEAK disclaims all liability for any such unauthorized use.